

Thermostatic Steam Trap



膜片溫差式輸水閥

- ▶ 可置於管線、熱交換器高處，作蒸氣排氣閥用
 - ▶ 體積小，重量輕，排量，抗結凍
 - ▶ 不可用於過熱蒸汽
-
- ▶ Can be placed in top of pipelines, heat exchangers for steam exhaust valve.
 - ▶ Small size, light weight, large displacement, anti-gelatinized.
 - ▶ Not be used for superheated steam.

材質表 CONSTRUCTION OF MATERIALS

BODY	本體	TRAP NO. TS-61 ASTM A216 GR. WCB	鑄鋼
		TRAP NO. TS-70 S.S.304	不銹鋼
CAGE UNIT	膜盒	STAINLESS STEEL	不銹鋼
DIAPHRAGM	膜片	STAINLESS STEEL	不銹鋼
SENSING FLUID	填充液	MIXED CHEMICAL	混合液
STRAINER	過濾器	STAINLESS STEEL	不銹鋼

- ▶ MOP/最高操作壓力、溫度: 22KG/CM² x 220°C
- ▶ 連續排水量表，公斤/小時

CONTINUOUS DISCHARGE CAPACITY OF CONDENSATE IN KG/HR

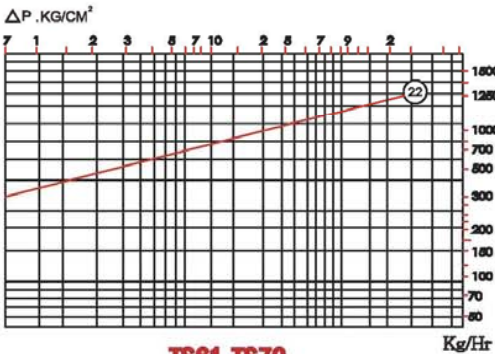

TS61 TS70

選擇時需考慮2至3倍的安全係數

- | | |
|-------------|--------------------------|
| ▶ 相關其他產品 | ▶ Other products |
| 1. 高低壓空氣祛水器 | 1. Air trap |
| 2. 水用蒸氣排氣閥 | 2. Air Vent |
| 3. 汽水分離器 | 3. Air & Water Separator |
| 4. 冷凝水泵 | 4. Cooling water pump |

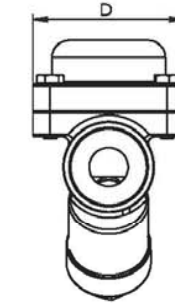
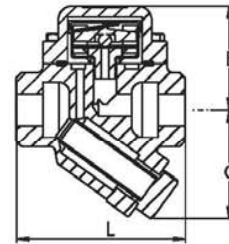
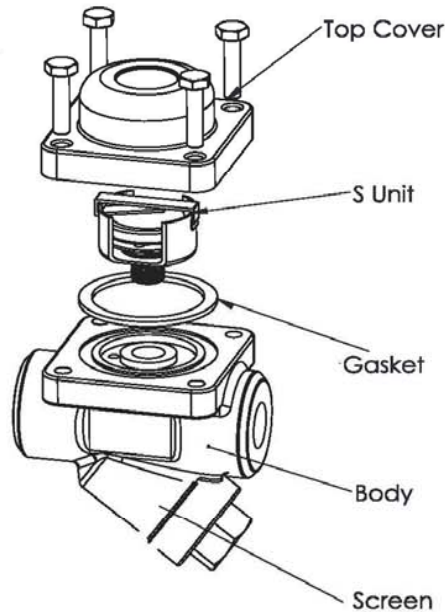

Trap No. TS61

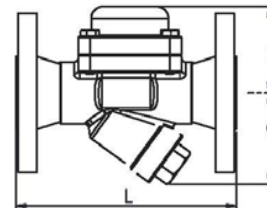

Trap No. TS61F

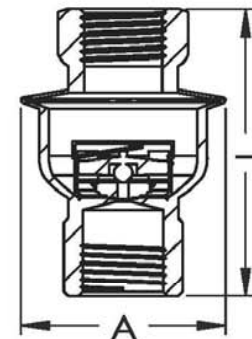

Trap No. TS70

TS61 Screwed Thermostatic Steam Trap Dimension

Model	Size(DN)	L	B	C	D	MOP	Weight
TS61	15.20	95	59	62	70	46	1.3
	25	95	59	62	70	46	1.4

TS61F Flanged Thermostatic Steam Trap Dimension

Model	Size(DN)	L	B	C	D	MOP	Weight
TS61F	15	150	59	62	70	46	4
	20	150	59	62	70	46	5.3
	25	160	59	62	70	46	6.5

TS70 Screwed Thermostatic Steam Trap Dimension

No.	Size(DN)	A	L	MOP	Weight
TS70	8.10	47	69	22	0.17
	15	47	69	22	0.19
	20	47	69	22	0.25

