



# FSSX Series Steam Trap

## Stainless Steel F & T Steam Traps



鑄不銹鋼浮球式疏水閥

- ▶ 啟動時可排大量不凝結氣體
- ▶ 適合前端有控溫設備使用
- ▶ 連續排放, 噪音小
- ▶ 內有水封阻擋蒸氣, 節能效果佳
- ▶ 內部交換器內部真空時, 亦可由重力排水

- ▶ Stainless steel, not rust, suitable for corrosive environment and the health requirements of high places.
- ▶ Can charge non-condensing gas when starting.
- ▶ Suitable for front-end with temperature control devices.
- ▶ Continuous emissions, less noise.
- ▶ Within the water seal to block steam, energy-saving effect of good.
- ▶ Heat exchanger inside a vacuum, also can discharge by the gravity.

### 材質表

#### CONSTRUCTION OF MATERIALS

|                       |       |                     |     |
|-----------------------|-------|---------------------|-----|
| CAP & BODY            | 本體    | A351 CF8/A351 CF8M  | 不銹鋼 |
| FLOAT                 | 浮球    | STAINLESS STEEL 304 | 不銹鋼 |
| MECHANISM             | 機械結構  | STAINLESS STEEL 304 | 不銹鋼 |
| SEAT & VALVE          | 閥座    | HARDENED 440        | 硬鉻鋼 |
| AIR VENT CAGE         | 排氣閥殼  | STAINLESS STEEL304  | 不銹鋼 |
| DIAPHRAGM OF AIR VENT | 排氣閥膜片 | STAINLESS STEEL304  | 不銹鋼 |
| GASKET                | 墊片    | Graphite            | 石墨  |
| BOLTS                 | 螺絲    | STAINLESS STEEL     | 不銹鋼 |
| NUTS                  | 螺帽    | STAINLESS STEEL     | 不銹鋼 |

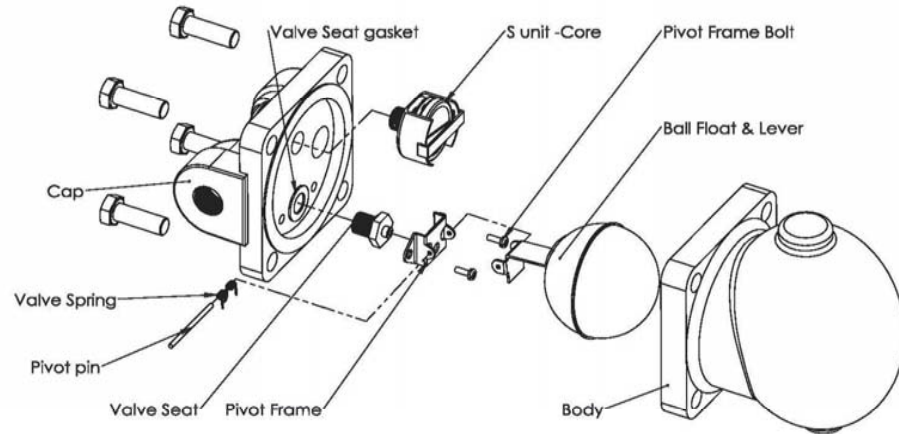

- ▶ Stainless Steel
- ▶ 不銹鋼: MOP/最高操作壓力、溫度:30KG/CM<sup>2</sup> x 320°C MAX.CAPACITY

連續排水量表, 公斤/小時

#### CONTINUOUS DISCHARGE CAPACITY OF CONDENSATE IN KG/HR

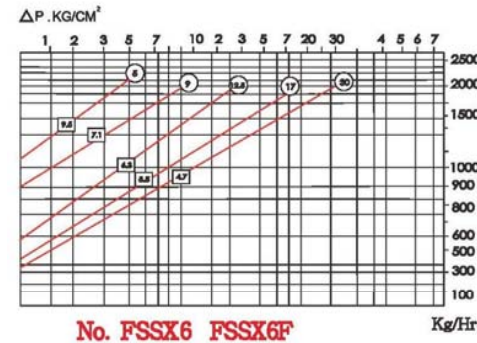
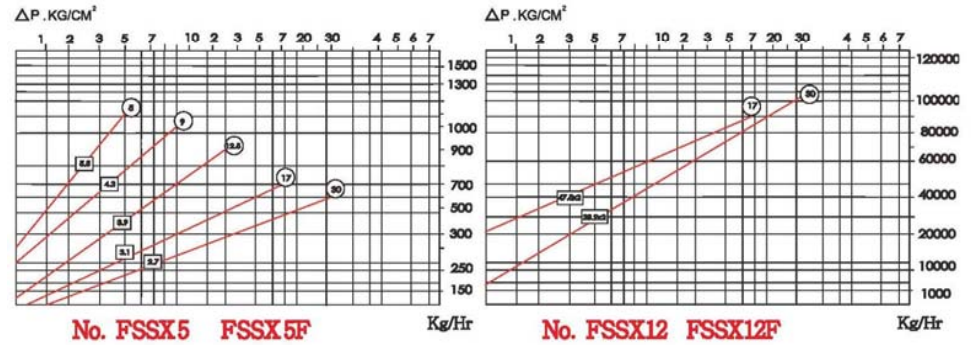
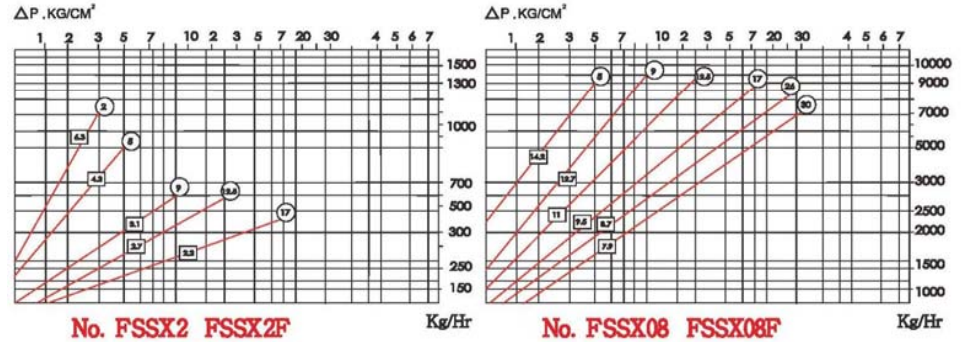

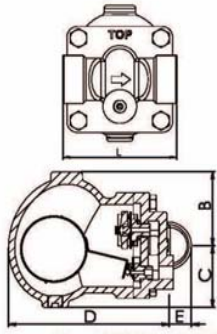

Trap No.FSSX2-FSSX08

TRAP FSSX2-FSSX08F SERIES DIMENSIONS(MM). MOP(KG/CM2) .WT(KG)

| TRAP NO. | CONN.SE.* | L   | B   | C   | D   | E  | MOP | WT   |
|----------|-----------|-----|-----|-----|-----|----|-----|------|
| FSSX2    | 15.20.25  | 118 | 68  | 68  | 174 | 20 | 17  | 6.5  |
| FSSX5    | 25.32     | 118 | 92  | 68  | 201 | 20 | 30  | 9    |
| FSSX6    | 32.40     | 146 | 100 | 85  | 242 | 40 | 30  | 20   |
| FSSX8    | 40.50     | 190 | 120 | 103 | 289 | 40 | 30  | 28.5 |
| FSSX08   | 40.50     | 190 | 170 | 103 | 352 | 43 | 30  | 34   |
| FSSX2F   | 15.25.50  | 215 | 68  | 68  | 174 | 20 | 17  | 8    |
| FSSX5F   | 25.32     | 215 | 92  | 68  | 201 | 20 | 30  | 11   |
| FSSX6F   | 32.40     | 285 | 100 | 85  | 242 | 40 | 30  | 22   |
| FSSX8F   | 40.50     | 310 | 120 | 103 | 289 | 40 | 30  | 31   |
| FSSX08F  | 32.40     | 310 | 170 | 103 | 352 | 43 | 30  | 36   |

\*NPT. PT. AVAILABLE VACUUM BREAKER AVAILABLE. PLS ADD "VB" TO TRAP NO.  
 所有型號皆可裝真空破除器。拆除排氣閥，均可作為鑄鋼浮球式空氣祛水器

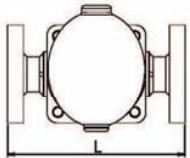

TRAP FSSX12 SERIES DIMENSIONS(MM). MOP(KG/CM2) .WT(KG)

| TRAP NO. | CONN.SE.* | L   | B   | C   | D   | E   | MOP | WT  |
|----------|-----------|-----|-----|-----|-----|-----|-----|-----|
| FSSX12   | 40.50     | 387 | 275 | 225 | 408 | 103 | 30  | 100 |
| FSSX12F  | 80.100    | 500 | 275 | 225 | 408 | 103 | 30  | 108 |

JIS 10K OR ANIS 150#RF STANDARD OTHER FLANGE SPEC. CONSULT FACTORY  
 FSSX12 FSSX12F DIMENSIONS.CONSULT FACTORY

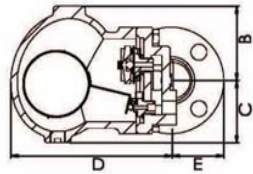

Trap No.FSSX2F-FSSX12F



S Unit

