



FSX Series Steam Trap



Cast Steel F & T Steam traps



鑄鋼浮球式疏水閥

- ▶ 啟動時可排大量不凝結氣體
- ▶ 適合前端有控溫設備使用
- ▶ 連續排放，噪音小
- ▶ 內有水封阻擋蒸氣，節能效果佳
- ▶ 內部交換器內部真空時，亦可由重力排水
- ▶ Stainless steel, not rust, suitable for corrosive environment and the health requirements of high places.
- ▶ Can charge non-condensing gas when starting.
- ▶ Suitable for front-end with temperature control devices.
- ▶ Continuous emissions, less noise.
- ▶ Within the water seal to block steam, energy-saving effect of good.
- ▶ Heat exchanger inside a vacuum, also can discharge by the gravity.

材質表

CONSTRUCTION OF MATERIALS

CAP & BODY	本體	A216.WCB	鑄鋼
FLOAT	浮球	STAINLESS STEEL 304	不銹鋼
MECHANISM	機械結構	STAINLESS STEEL 304	不銹鋼
SEAT & VALVE	閥座	HARDENED 440	硬鉻鋼
AIR VENT CAGE	排氣閥殼	STAINLESS STEEL 304	不銹鋼
DIAPHRAGM OF AIR VENT	排氣閥膜片	STAINLESS STEEL 304	不銹鋼
GASKET	墊片	Graphite	石墨
BOLTS	螺絲	CARBON STEEL	碳鋼
NUTS	螺帽	CARBON STEEL	碳鋼

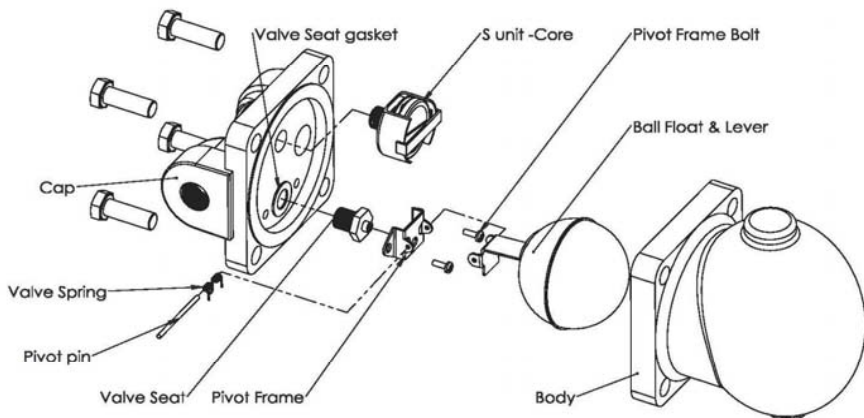

連續排水量表，公斤/小時

CONTINUOUS DISCHARGE CAPACITY OF CONDENSATE IN KG/HR

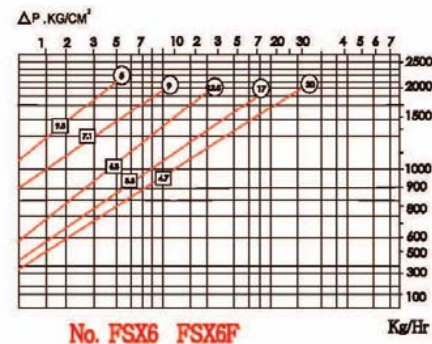
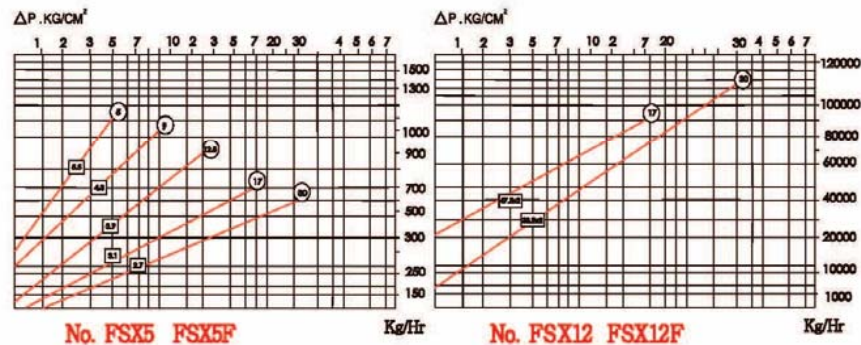
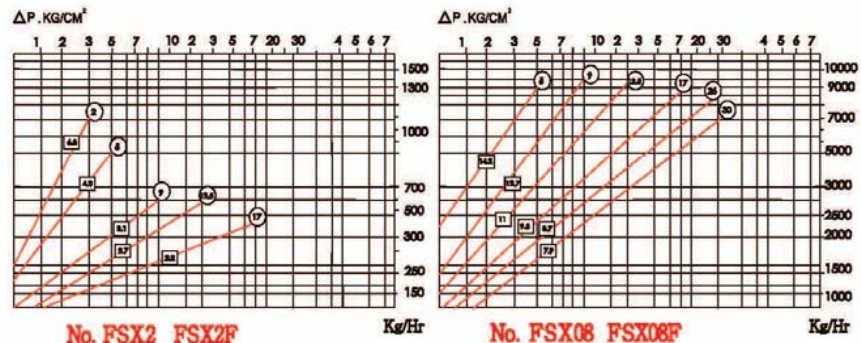

▶ Cast Steel

▶ 鑄鋼: MOP/最高操作壓力、溫度: 32KG/CM²(3.2Mpa) x 320°C MAX.CAPACITY/最大排量: 112000 KG/HR

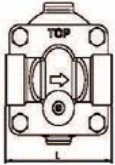

TRAP FSX2-FSX08F SERIES DIMENSIONS(MM), MOP(KG/CM²), WT(KG)

TRAP NO.	CONN.SE.*	L	B	C	D	E	MOP	WT
FSX2	15.20.25	118	88	88	174	20	17	6.5
FSX5	25.32	118	92	88	201	20	30	9
FSX6	32.40	146	100	85	242	40	30	20
FSX8	40.50	190	120	103	289	40	30	28.5
FSX08	40.50	190	170	103	352	43	30	34
FSX2F	15.25.50	215	88	88	174	20	17	8
FSX5F	25.32	215	92	88	201	20	30	11
FSX6F	32.40	285	100	85	242	40	30	22
FSX8F	40.50	310	120	103	289	40	30	31
FSX08F	32.40	310	170	103	352	43	30	36

*NPT, PT, AVAILABLE VACUUM BREAKER AVAILABLE. PLS ADD "VB" TO TRAP NO.
所有型號皆可裝真空破除器。拆除排氣閥，均可作為鑄鋼浮球式空氣排水器

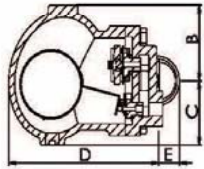

Trap No.FSX2-FSX08

TRAP FSX12 SERIES DIMENSIONS(MM), MOP(KG/CM²), WT(KG)

TRAP NO.	CONN.SE.*	L	B	C	D	E	MOP	WT
FSX12	40.50	387	275	225	408	103	30	100
FSX12F	80.100	500	275	225	408	103	30	108

JIS 10K OR ANIS 150#RF STANDARD OTHER FLANGE SPEC. CONSULT FACTORY
FX12 FX12F DIMENSIONS CONSULT FACTORY

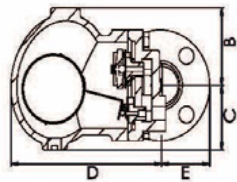
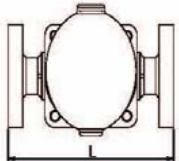

Trap No.FSX2F-FSX12F

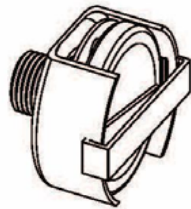

S Unit

