

**Bellow Globe Valve**

**波紋管截止閥**
**應用範圍:**  
 蒸汽、熱油  
 熱水/冷水  
 系統

**Application:**  
 Steam, Thermal oil  
 Hot/Cold Water  
 system

**特點 ▶ Description** 栓接閘蓋 BOLTED BONNET  
 明杆支架 OUTSIDE SCREW AND YOKE  
 上升閘杆 RISING STEM  
 無上升手輪 NON RISING HANDWHEEL  
 活動閘瓣 LOOSE DISC

**設計 ▶ Design** DIN 3356

**規範 ▶ Face to face** DIN 3202

**▶ Flanges** DIN 2501  
 DIN 2547  
 DIN 2526 FORM E  
 BW TO DIN 3239

**測試 ▶ Testing** DIN 3352 Part 1  
 DIN 3230 Part 3

**等級 ▶ Rating** DIN 2401

**▶ Marking** EN 19  
 CE - PED

**材質表**
**CONSTRUCTION OF MATERIALS**

部件	PART NAME	MATERIAL	
閘體	Body	1.0619	1.4581
閘座	Seat surface	X20Cr13(1) overlay	1.4581(1) overlay
閘瓣	Disc seat surface	X20Cr13(2) overlay	1.4581(2) overlay
波紋管	Bellows	SS304/SS321/SS316L	SS321/SS316L
墊片	Gasket	S.S.reinforced graphite(4)	S.S.reinforced graphite(4)
螺母	Nuts	C35	A2-70
螺絲	Bolts	CK35	A2-70
填料	Packing	Graphite rings & wiper rings (4)	Graphite rings & wiper rings
壓蓋	Gland	1.0460	X5CrNiMo17-12-2 (2)
閘蓋	Bonnet	1.0619	1.4581
閘桿	Stem	X20Cr13(2)	X5CrNiMo17-12-2 (2)
支架螺母	Yoke Nut	GGG40(3)	Cu-Alloy
支架鎖片	Lock Nut	C.S	C.S
把手	Handwheel	Steel	Steel
卡簧	Circlip	65Mn	65Mn

**Maximum pressure under the disc**

DN	80	100	125	150	200	250	300	350	400
Δp bar	85	60	35	21	14	9	6	5	4

If higher, valve to be mounted with gear operator or with pressure above the disc and fitted with external or internal bypass.

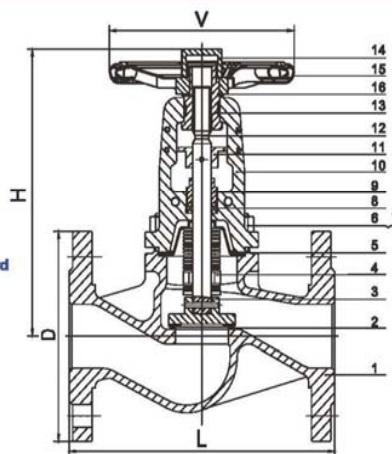
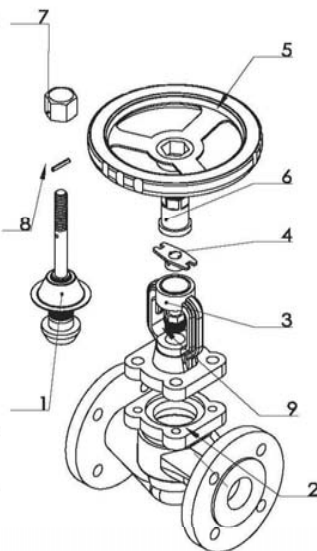
**G061 BELLOWS SEAL STOP VALVES DIN PN16 - FACE TO FACE F1**

SIZE DN	15	20	25	32	40	50	65	80	100	125	150	200	250	300	350	400
LRF	130	150	160	180	200	230	290	310	350	400	480	600	730	850	980	1100
D	95	105	115	140	150	165	185	200	220	250	285	340	405	480	520	580
V	120	140	140	140	160	160	180	200	250	250	350	450	500	500	600	600
H	196	196	205	205	222	224	240	265	350	380	410	550	715	790	950	1030
STROKE	8	8	10	10	15	16	18	22	28	34	40	60	75	85	100	115

**G062 BELLOWS SEAL STOP VALVES DIN PN25 - Face to Face F1**

SIZE DN	15	20	25	32	40	50	65	80	100	125	150	200	250	300	350	400
LRF	130	150	160	180	200	230	290	310	350	400	480	600	730	850	980	1100
D	95	105	115	140	150	165	185	200	235	270	300	360	425	485	555	620
V	140	140	160	160	180	180	200	250	300	350	400	500	500	500	600	600
H	196	196	205	205	222	224	240	265	350	380	410	550	715	790	950	1030
STROKE	8	8	10	10	15	16	18	22	28	34	40	60	75	85	100	115

**G063 BELLOWS SEAL STOP VALVES DIN PN40 - Face to Face F1**

SIZE DN	15	20	25	32	40	50	65	80	100	125	150	200	250	300	350	400
LRF	130	150	160	180	200	230	290	310	350	400	480	600	730	850	980	1100
D	95	105	115	140	150	165	185	200	235	270	300	375	450	515	580	660
V	140	140	160	160	180	180	200	200	300	350	400	500	500	500	600	600
H	196	196	205	205	222	224	240	265	350	380	410	550	715	790	950	1030
STROKE	8	8	10	10	15	16	18	22	28	34	40	60	75	85	100	115