

## 2-PC Ball Valve Screwed End



2片式絲口球閥

### FEATURES 特點

- ▶ Pipe thread in accordance with ANSI B2.1, BS 21:1973,
- ▶ DIN 259/2999, ISO 228
- ▶ Pressure rating: 1000 PSI
- ▶ Investment casting body and cap
- ▶ Blow-out proof stem

### OPTION 選項

- ▶ Wing handle
- ▶ SEATS/PACKING: R-PTFE/GRAPHITE
- ▶ Locking device

### EXPLOSION DRAWING 爆炸圖

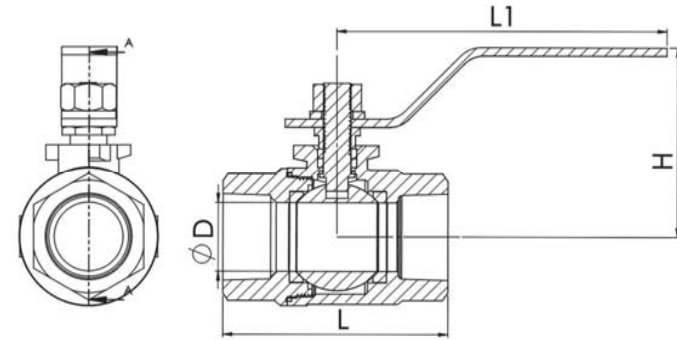
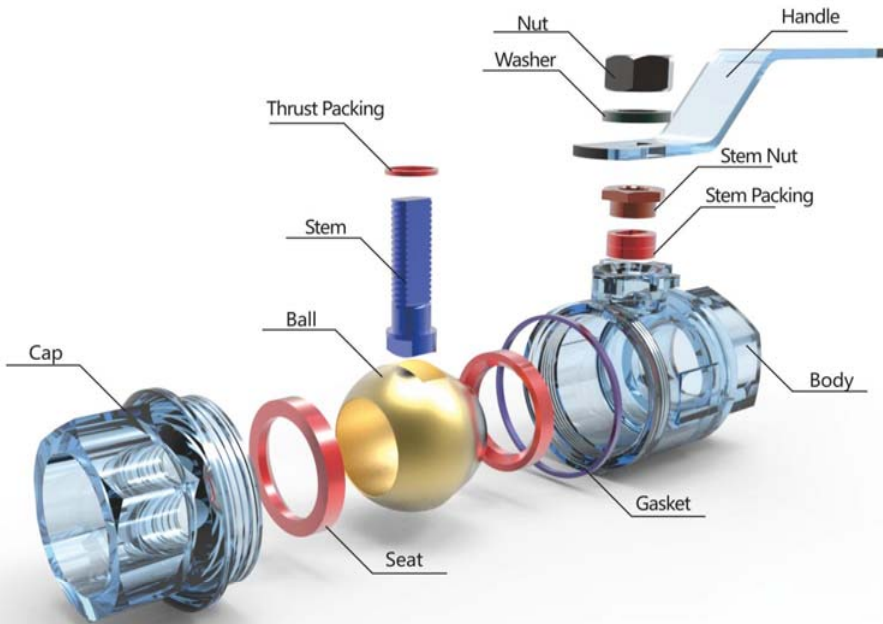

### MATERIAL LIST 材質表

ITEM	部件	PART	MATERIALS				
			304	304L	316	316L	WCB
1	外六角螺母	Nut	A193 B8/Customize				
2	外六角螺栓	Bolt	A193 B8/Customize				
3	填料壓蓋	Gland	A351-CF8	A351-CF3	A351-CF8M	A351-CF3M	A216-WCB
4	中道墊片	Gasket	PTFE Or Optional (See Page4)				
6	填料	Packing	PTFE Or Graphite				
5	閥蓋	CAP	A351-CF8	A351-CF3	A351-CF8M	A351-CF3M	A216-WCB
7	閥座	Seat	PTFE Or Optional (See Page4)				
8	球體	Ball	A182 F304	A182 F304L	A182 F316	A182 F316L	A276-420
9	止退墊	Thrust Packing	PTFE Or Optional (See Page4)				
10	O型圈	O Ring	Viton / NBR				
11	閥杆	Stem	A182 F304	A182 F304L	A182 F316	A182 F316L	A276-420
12	閥體	Body	A351-CF8	A351-CF3	A351-CF8M	A351-CF3M	A216-WCB

### DIMENSION 尺寸表

SIZE	D	L	H	L1	WT (kg)
1/4"	11.5	52	52	100	0.216
3/8"	12.7	52	52	100	0.216
1/2"	15	54	54	105	0.23
3/4"	20	62	58	105	0.29
1"	25	71	64	109	0.47
1-1/4"	32	82	75	125	0.829
1-1/2"	38	93	80	158	1.28
2"	50	107	90	168	1.95
2-1/2"	65	148	129	202	4.8
3"	80	164	137	242	7.68
4"	100	198	145	275	13.36